

CUSTOMISE NOZZLE FOR SPECIFIC COMPONENT  
(eg.CONNECTOR)

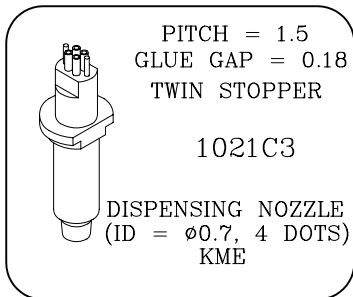

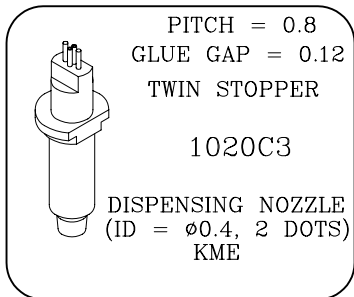

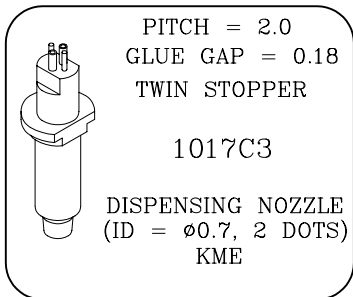
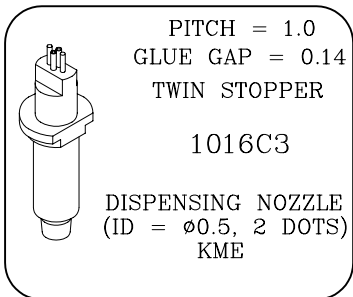
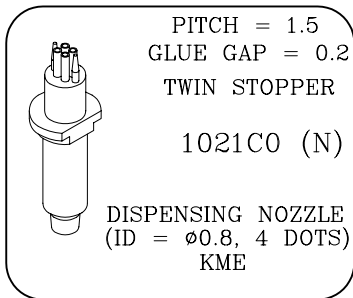
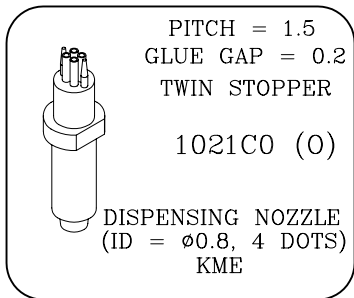
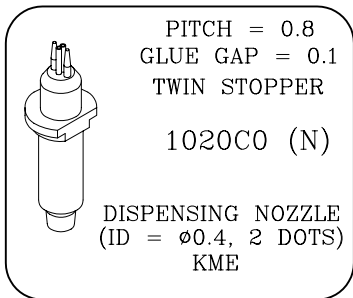
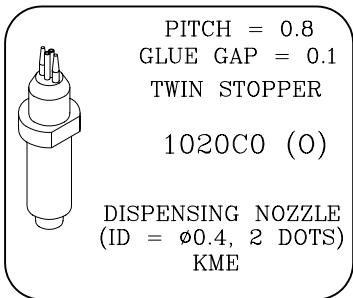
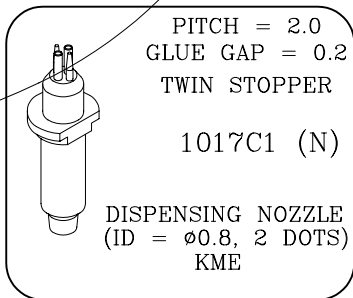
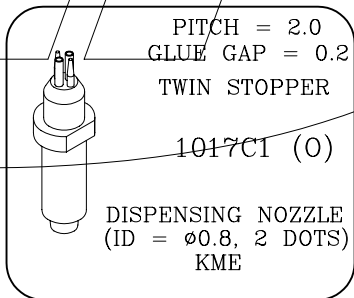
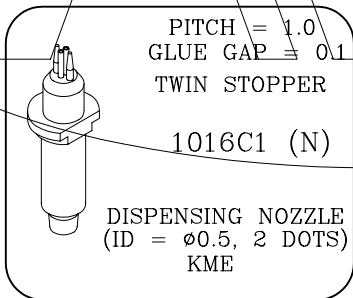
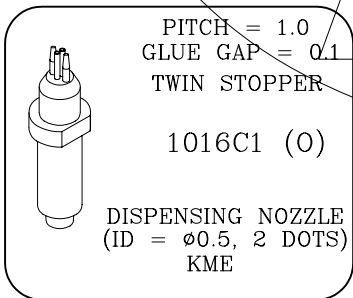
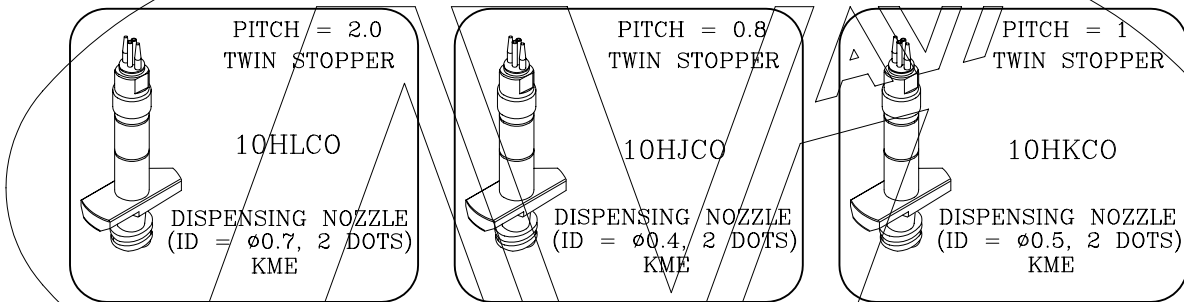
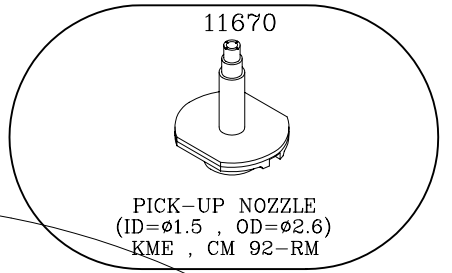
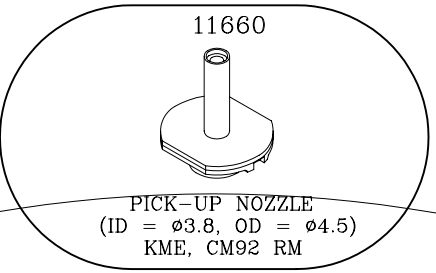
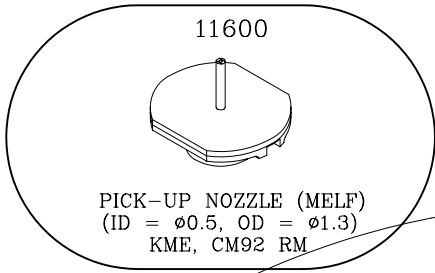
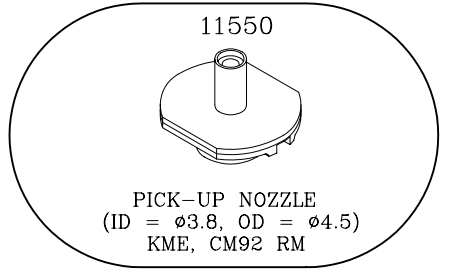
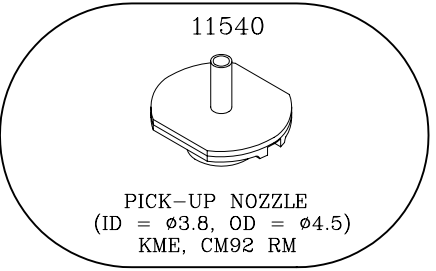
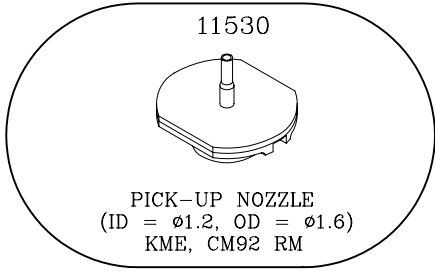
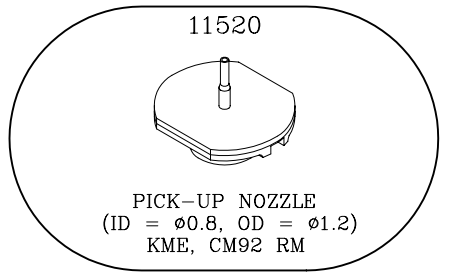
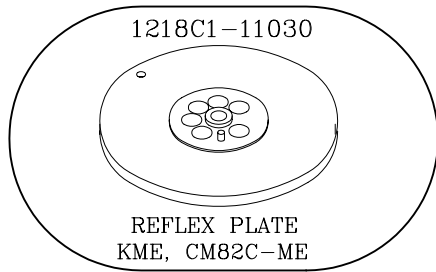
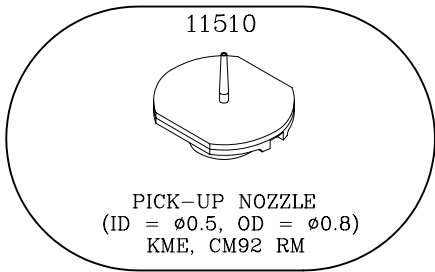
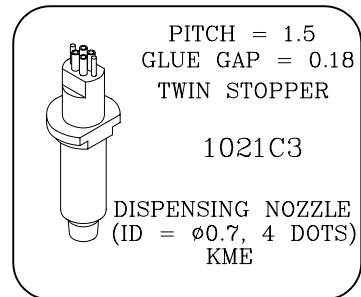
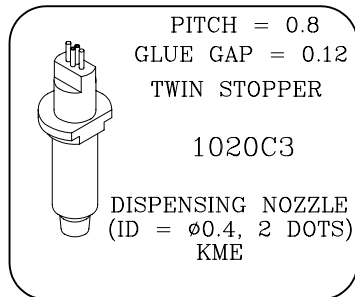
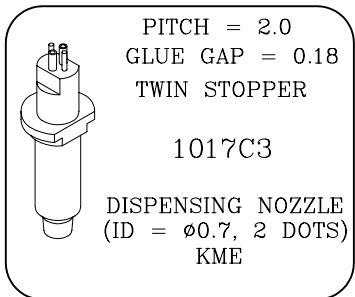
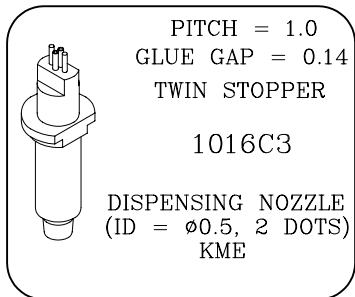
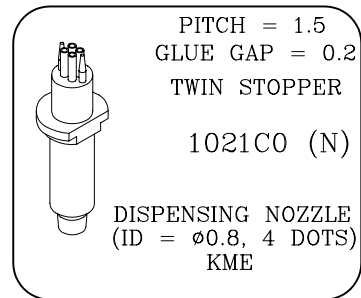
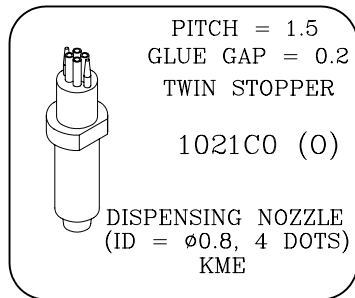
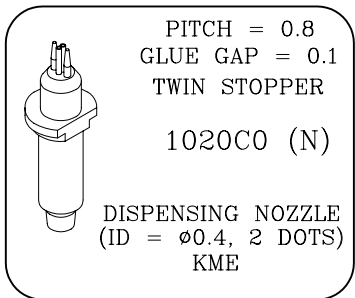
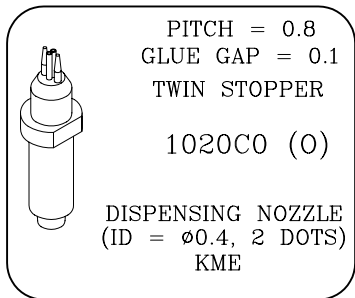
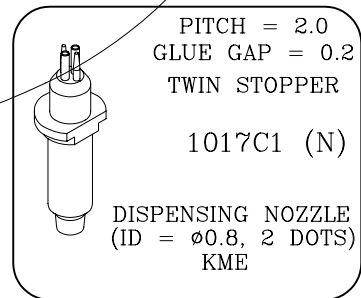
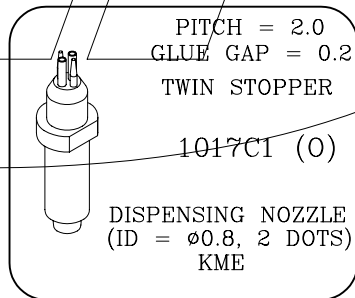
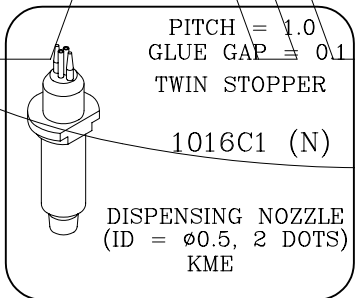
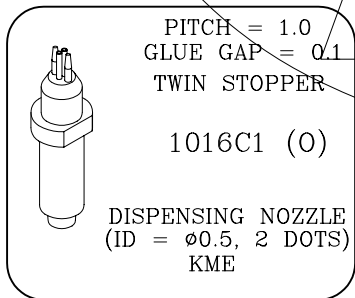
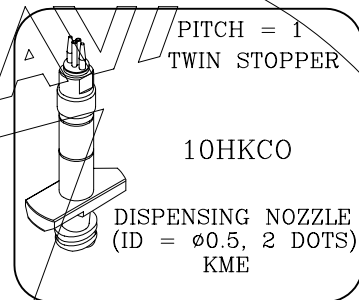
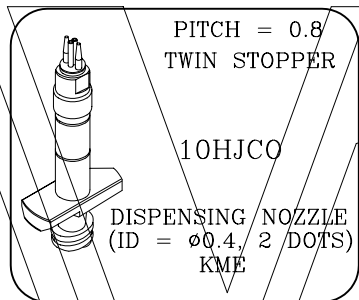
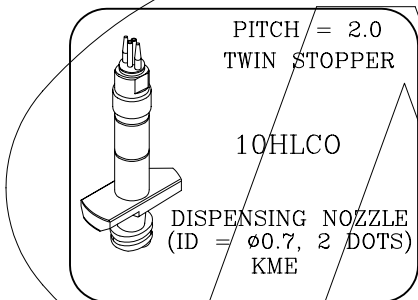
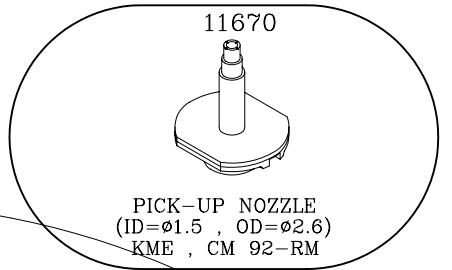
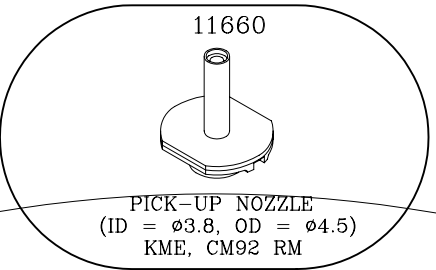
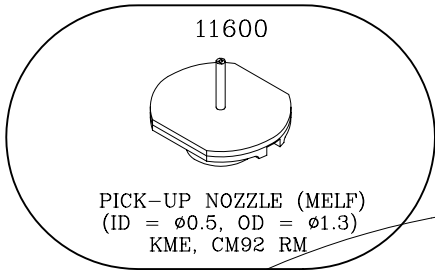
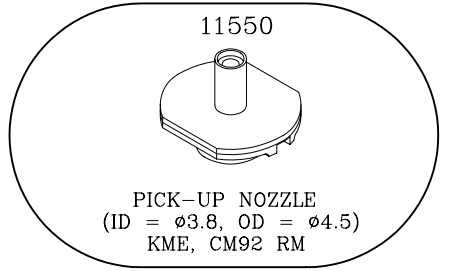
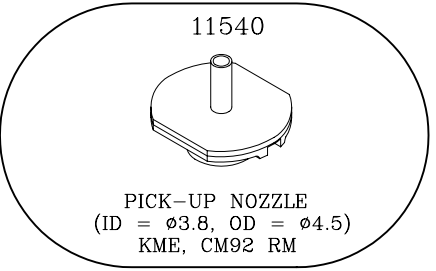
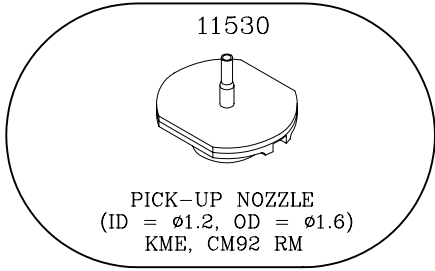
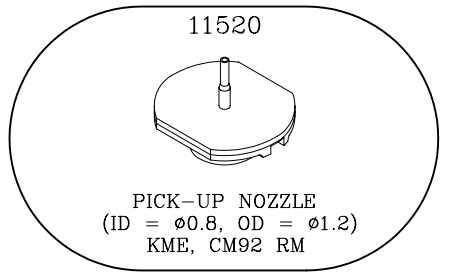
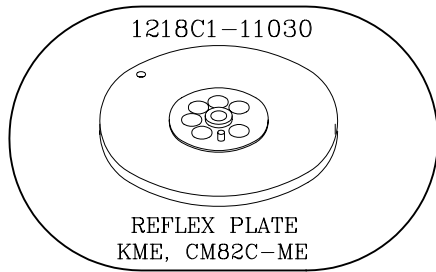
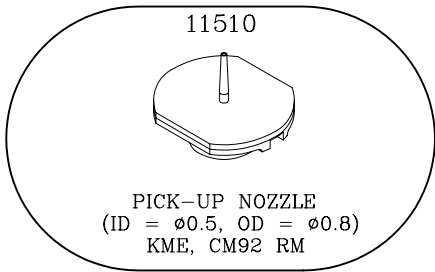
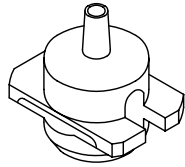

1011C1-15010  
PICK-UP NOZZLE  
KME, CM 60/62

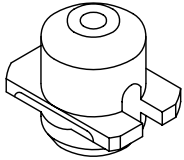

1011C1-15060  
PICK-UP NOZZLE  
KME, CM 60/62

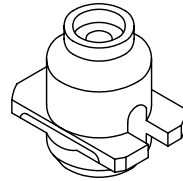

1011C1-15120  
PICK-UP NOZZLE  
KME, CM 60/62

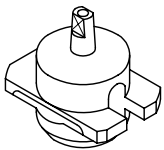

1011C1-19010  
PICK-UP NOZZLE  
(ID =  $\phi 0.7$ , OD =  $\phi 1.3$ )  
KME, CM92-MT

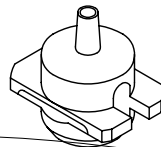

1011C1-19020  
PICK-UP NOZZLE  
(ID =  $\phi 1.0$ , OD =  $\phi 1.3$ )  
KME, CM92-MT

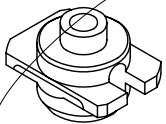

1011C1-19030  
PICK-UP NOZZLE  
(ID =  $\phi 1.8$ , OD =  $\phi 3.0$ )  
KME, CM92-MT

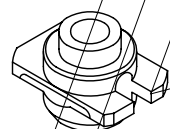

1011C1-19040  
PICK-UP NOZZLE  
(ID =  $\phi 2.5$ , OD =  $\phi 4.0$ )  
KME, CM92-MT

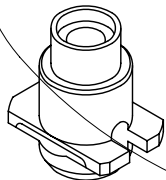

1011C1-19050  
PICK-UP NOZZLE  
(ID =  $\phi 3.8$ , OD =  $\phi 4.5$ )  
KME, CM92-MT

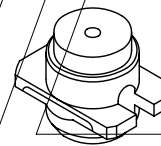

1011C1-19060  
PICK-UP NOZZLE  
(ID =  $\phi 1.0$ , OD =  $\phi 5.0$ )  
KME, CM92-MT

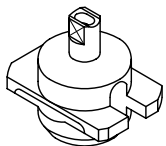

1011C1-19070  
PICK-UP NOZZLE (MELF)  
(ID =  $\phi 0.9$ , OD =  $\phi 2.0$ )  
KME, CM92-MT

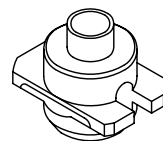

1011C1-19080  
PICK-UP NOZZLE  
(ID =  $\phi 2.5$ , OD =  $\phi 3.0$ )  
KME, CM92-MT

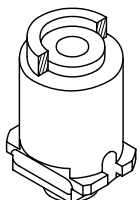

1011C1-19013  
PICK-UP NOZZLE  
(ID =  $\phi 5.0$ , OD =  $\phi 7.0$ )  
KME, CM92-MT

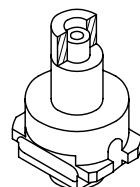

1011C1-19100  
PICK-UP NOZZLE  
(ID =  $\phi 2.0$ , OD =  $\phi 4.0$ )  
KME, CM92-MT

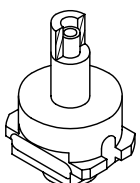

1011C1-19120  
PICK-UP NOZZLE  
(ID =  $\phi 1.5$ , OD =  $\phi 3.0$ )  
KME, CM92-MT

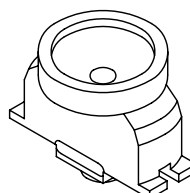

1011C1-19130  
PICK-UP NOZZLE  
(ID =  $\phi 10.0$ , OD =  $\phi 12.5$ )  
KME, CM92-MT

1227C1-12061 3216 CHIP



PICK-UP NOZZLE  
(ID =  $\phi$ 1.4, OD =  $\phi$ 1.8)  
KME , CM85C-M/L

1227C1-12071 2125 CHIP



PICK-UP NOZZLE  
(ID =  $\phi$ 0.9, OD =  $\phi$ 1.3)  
KME , CM85C-M/L

1227C1-12081 1608 CHIP



PICK-UP NOZZLE  
(ID = \* $\phi$ 0.6, OD =  $\phi$ 0.9)  
KME , CM85C-M/L

1227C1-12091 1005 CHIP



PICK-UP NOZZLE  
(ID = \* $\phi$ 0.4, OD =  $\phi$ 0.6)  
KME , CM85C-M/L

1227C1-12131 MELF



PICK-UP NOZZLE  
(ID =  $\phi$ 0.9, OD =  $\phi$ 1.3)  
KME , CM85C-M/L

1222C2-11132 1005 CHIP

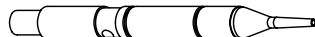

PICK-UP NOZZLE  
(ID = \* $\phi$ 0.4, OD =  $\phi$ 0.6)  
KME , CM86

1222C2-11142 1608 CHIP

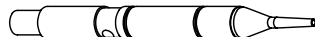

PICK-UP NOZZLE  
(ID = \* $\phi$ 0.6, OD =  $\phi$ 0.9)  
KME , CM86

1222C2-11152 2125 CHIP

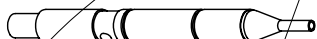

PICK-UP NOZZLE  
(ID =  $\phi$ 0.9, OD =  $\phi$ 1.3)  
KME , CM86

1222C2-11162 MELF

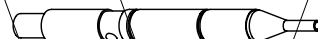

PICK-UP NOZZLE  
(ID =  $\phi$ 0.9, OD =  $\phi$ 1.3)  
KME , CM86

1222C2-11172 3216 CHIP

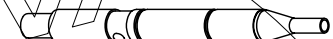

PICK-UP NOZZLE  
(ID =  $\phi$ 1.4, OD =  $\phi$ 1.8)  
KME , CM86

1218C1-12062 3216 CHIP



PICK-UP NOZZLE  
(ID =  $\phi$ 1.2, OD =  $\phi$ 1.6)  
KME , CM82C-ME

1218C1-12072 2125 CHIP



PICK-UP NOZZLE  
(ID =  $\phi$ 0.9, OD =  $\phi$ 1.2)  
KME , CM82C-ME

1218C1-12082 1608 CHIP



PICK-UP NOZZLE  
(ID =  $\phi$ 0.5, OD =  $\phi$ 0.8)  
KME , CM82C-ME

1218C1-12092 1005 CHIP



PICK-UP NOZZLE  
(ID = \* $\phi$ 0.3, OD =  $\phi$ 0.6)  
KME , CM82C-ME

1218C1-12112 SOP



PICK-UP NOZZLE  
(ID =  $\phi$ 2.3, OD =  $\phi$ 3.0)  
KME , CM82C-ME

1218C1-12132 MELF



PICK-UP NOZZLE  
(ID =  $\phi$ 0.9, OD = \* $\phi$ 1.2)  
KME , CM82C-ME

1227C0-12061 3216 CHIP



PICK-UP NOZZLE  
(ID =  $\phi$ 1.2, OD =  $\phi$ 1.6)  
KME , CM82C-MG

1227C0-12071 2125 CHIP



PICK-UP NOZZLE  
(ID =  $\phi$ 0.9, OD =  $\phi$ 1.2)  
KME , CM82C-MG

1227C0-12081 1608 CHIP



PICK-UP NOZZLE  
(ID =  $\phi$ 0.5, OD =  $\phi$ 0.8)  
KME , CM82C-MG

1227C0-12091 1005 CHIP



PICK-UP NOZZLE  
(ID = \* $\phi$ 0.3, OD =  $\phi$ 0.6)  
KME , CM82C-MG

1227C0-12111 SOP



PICK-UP NOZZLE  
(ID =  $\phi$ 2.3, OD =  $\phi$ 3.0)  
KME , CM82C-MG

1227C0-12131 MELF



PICK-UP NOZZLE  
(ID =  $\phi$ 0.9, OD = \* $\phi$ 1.2)  
KME , CM82C-MG